



hurlcon

BX series pool and spa pumps

How do you make the best pump even better? With the TX Series pool and spa pumps, Hurlcon set a new benchmark in performance and durability.

Now the challenge is to increase performance and, at the same time, make it even quieter.

In a world where increased power and increased noise go together that may sound like a contradiction, but with the new BX Series it's now an amazing reality.

BX

Hurlcon BX series pool and spa pumps



The demands on modern pumps are constantly rising. Large in-ground pools, swim spas, swim jets, larger pool filters, salt chlorinators, in-floor cleaning systems and multi jet spas all place an enormous load on the pump. That's why the Hurlcon BX Series has so much brute power and control. It has been designed to comfortably meet these demands by delivering much higher head pressures and superior overall performance. And surprisingly, it does it while setting new standards of efficiency, convenience and at greatly reduced noise levels.

A new low in Noise Levels.

In high density residential areas, noise is an issue so the BX was designed to be very, very quiet. This new benchmark in low noise operation was achieved by the use of high quality materials and rigid construction.

A finned motor that runs cooler with less fan noise also helped. And the use of 50mm or 65mm barrel unions meant less cavitation, lower pressure drop and consequently, much lower noise.

A new high in Efficiency.

BX also moves more water, using less power, in fewer hours per day. Fewer operating hours means lower operating costs.

A new benchmark in Convenience.

The huge hair and lint pot on the BX requires less frequent cleaning, making it ideal for holiday homes

and high leaf areas. The clear inspection lid is removed with a simple twist and the strainer basket is self-locating so it can never block the inlet.

A choice of 65mm or 50mm Inlet and outlet barrel union connections allow for quick and easy installation and removal for servicing and is ideal for commercial applications.

The same Hurlcon Reliability.

The BX body is a single piece of super tough, corrosion-resistant, high-tech, glass-reinforced thermoplastic.

The combination of premium materials and large capacity makes the BX ideal for commercial applications.



Quality Components.

Internally, stainless steel shafts and 'lapped true carbon face and ceramic seals' also help achieve the highest standards of reliability and durability.

Genus Technology.

The BX Series is not just a pump, its part of a family of high quality, highly intelligent, interconnected products that together, take total care of your pool and spa.

The Genus IV controller links all the separate components together through a single control that allows any member of the family to operate

the system. (Full Genus IV system is sold separately).

Wide Range.

The Hurlcon BX Series Pool and Spa Pumps are available in 4 sizes from 1.0 horsepower to 3 horsepower and most models are available in 415 V 3 Phase power supply.

Warranty.

Each pump is covered by a limited 3 year warranty against defects in materials and workmanship. For full details refer to the BX Series Instruction Sheet.

Specifications.

Model	Volts	Phase	Input Watts	Horse Power	Flow Rate @ 8 m/h	Max Noise Full Load @ 1 mtr	Full Load Amps
BX 1.0	240	Single	1300	1.00	325 lpm	60 dBA	5.5
BX 1.5	240	Single	1640	1.50	440 lpm	60 dBA	6.6
BX 2.0	240	Single	2020	2.00	540 lpm	62 dBA	8.5
BX 3.0	240	Single	2300	3.00	635 lpm	62 dBA	12.5

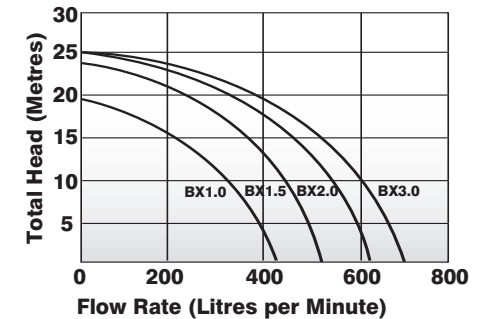
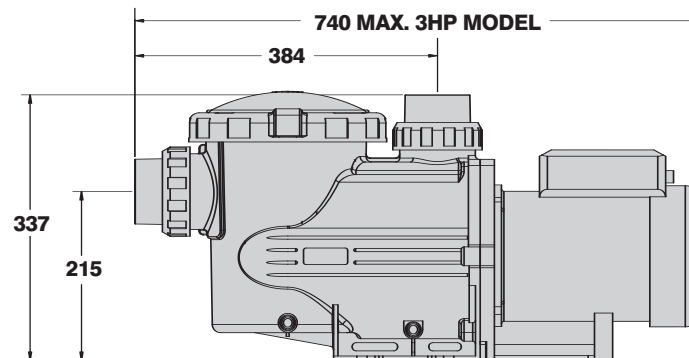

Available from:



Order Free Fax 1800 635 781
or sales@hurlcon.com.au

Victorian Office:
Ph: 03 9765 9765
Fax: 03 9764 9009

NSW Office:
Ph: 02 9674 8544
Fax: 02 9674 8522

Queensland Office:
Ph: 07 3393 3233
Fax: 07 3393 3255

South Australian Office:
Ph: 08 8345 5755
Fax: 08 8345 5211

Western Australian Office:
Ph: 08 9258 9322
Fax: 08 9258 9344